



The Arunachal Pradesh Gazette

EXTRAORDINARY
PUBLISHED BY AUTHORITY

No. 453 Vol. XXIII, Naharlagun, Friday, December 9, 2016, Agrahayana 18, 1938 (Saka)

ARUNACHAL PRADESH STATE ELECTRICITY REGULATORY COMMISSION

NOTIFICATION

The 7th December, 2016

ROOFTOP SOLAR GRID INTERACTIVE SYSTEMS BASED ON NET METERING

No. APSERC /NOTIFICATION/21 /2016.—In exercise of powers conferred under sections 61, 66, 86(1)(e) and 181 of the Electricity Act, 2003 (Act 36 of 2003) and all other powers enabling it in this behalf, and after previous publication, the Arunachal Pradesh State Electricity Regulatory Commission hereby makes the following regulations for the grid connected Solar Rooftop Photovoltaic system :

1. **Short title and commencement** : These regulations may be called the **Arunachal Pradesh State Electricity Regulatory Commission (Rooftop Solar Grid Interactive systems based on Net metering) Regulations, 2016**.

1.1 These regulations shall come into force from the date of their notification in the Gazette of Arunachal Pradesh.

2. **Definitions and Interpretations** : 2.1 In these regulations, unless the context otherwise requires,

- (a) "Act" means the Electricity Act, 2003 (36 of 2003) and subsequent amendments thereof ;
- (b) "agreement" means an agreement entered into by the Distribution licensee and the consumer ;
- (c) "billing cycle or billing period" means the period for which regular electricity bills as specified by the Commission, are prepared for different categories of consumers by the licensee ;
- (d) "Commission" means the Arunachal Pradesh State Electricity Regulatory Commission constituted under the Act ;
- (e) "consumer" means any person who is supplied with electricity for his own use by a licensee or the Government or by any other person engaged in the business of supplying electricity to the public under this Act or any other law for the time being in force and includes any person whose premises are, for the time being, connected for the purpose of receiving electricity with the works of a distribution licensee, the Government or such other person, as the case may be ;
- (f) "contracted load" or "contract demand" means the maximum demand in kW, kVA or BHP, agreed to be supplied by the licensee and indicated in the agreement executed between the licensee and the consumer ;
- (g) "Distribution licensee" or "licensee" means a person granted a license under Section 14 of the Act authorizing him to operate and maintain a distribution system for supplying electricity to the consumers in his area of supply ;
- (h) "Electricity Supply Code" means the Arunachal Pradesh Electricity Supply Code - 2013 notified under section 50 of the Act and any subsequent amendments thereof ;
- (i) "eligible consumer" means a consumer of electricity in the area of supply of the distribution licensee, who uses a rooftop solar system installed in the consumer premises, to offset part or all of the consumer's own electrical requirements, given that such systems can be self-owned or third party owned ;
- (j) "financial year" or "year" means the period beginning from first of April in an English calendar year and ending with the thirty first of the March of the next year ;
- (k) "Grid Interactive System" (GIS) means a system that connects the Solar power generating plant in an electricity consumer's premises to an utility grid, so as to supply excess electricity to the distribution company's grid, after meeting the need of consumer and also to draw electricity from the grid to meet the shortfall when sufficient electricity is not produced by the generating plant. Import-export and net energy consumed or injected is measured by 'net metering'.
- (l) "Interconnection Point" means the interface of the Solar power generating facility with the network of distribution licensees and the 'Interconnection Point' for such facility shall be the outgoing terminals of the meter, if the meter is fixed after the Distribution Licensee's cut-outs/ switchgear in the premises of the Eligible Consumer and the Distribution Licensee's cut-outs/ switchgear, if the meter is fixed before the Distribution Licensee's cut-outs/switchgear.

- (m) "invoice" means either a Monthly Bill/Supplementary Bill or a Monthly Invoice/Supplementary Invoice raised by the distribution licensee
- (n) "kWp" means kilo Watt peak ;
- (o) "net metering" means an arrangement under which rooftop solar system the system installed at eligible consumer premises delivers surplus electricity, if any, to the Distribution Licensee after off setting the electricity supplied by distribution licensee during the applicable billing period
- (p) "obligated entity" means the entity mandated under clause (e) of sub-section (1) of section 86 of the Act to fulfill the renewable purchase obligation and identified under Renewable Power Purchase Obligations and its Compliance - 2012 and as amended upto date
- (q) "premises" means rooftops or/and elevated areas on the land, building or infrastructure or part or combination thereof in respect of which a separate meter or metering arrangements have been made by the licensee for supply of electricity.
- (r) "rooftop solar system" means the solar photo voltaic power system installed on the rooftops of consumer premises that uses sunlight for direct conversion into electricity through photo voltaic technology .
- (s) "Renewable Energy Certificate (REC)" means the certificate issued in accordance with the procedures approved by the Central Electricity Regulatory Commission ,
- (t) "settlement period" means the period beginning from first of April in an English calendar year and ending with the thirty first of the March of the next year .
- (u) "tariff order" in respect of a licensee means the most recent order issued by the Commission for that licensee indicating the rates to be charged by the licensee from various categories of consumers for supply of electrical energy and services ,

2.2 All other words and expressions used in these Regulations although not specifically defined herein above, but defined in the Act, shall have the meaning assigned to them in the Act. The other words and expressions used herein but not specifically defined in these Regulations or in the Act but defined under any law passed by the Parliament applicable to the electricity industry in the State shall have the meaning assigned to them in such law

3 Scope and application : 3.1 These Regulations shall apply to the distribution licensee and consumers of electricity of distribution licensee of the State of Arunachal Pradesh.

3.2 A Rooftop Solar Grid Interactive System installed in the premises of an eligible consumer may be either owned by him or a 3rd party.

3.3 The eligible consumer may install the rooftop solar system under net metering arrangement which,

- shall be within the permissible rated capacity as defined under these Regulations
- shall be located in the consumer premises.
- shall interconnect and operate safely in parallel with the distribution licensee network

3.3 These regulations do not preclude the right of relevant state authorities to undertake rooftop solar projects above 1 MWp capacity through alternative mechanisms.

4 General Principles : 4.1 The distribution licensee shall offer the provision of net metering arrangement to the consumer, who intends to install grid connected rooftop solar system, in its area of supply on non-discriminatory and first come first serve basis.

Provided that the distribution licensee shall offer the provision of net metering to the consumer for the target capacity as specified under these Regulations ,

Provided further that the consumer is eligible to install the grid connected rooftop solar system of the rated capacity as specified under these Regulations ,

Provided also that the interconnection of such system with the grid is undertaken as specified under these Regulations and the relevant technical standards notified by the CEA for connectivity with the grid.

5 Capacity Targets for distribution licensee : 5.1 The distribution licensee shall provide net metering arrangement to eligible consumers as long as the total capacity (in MW) does not exceed the target capacity determined by Commission,

Provided a maximum cumulative capacity as mentioned below shall be allowed to eligible consumers under net metering, in the area of supply of the distribution licensee as per the following target

FY 2016-17 = 6MW FY 2018-19 = 8 MW FY 2020-21 = 10 MW

FY 2017-18 = 6MW FY 2019-20 = 10 MW FY 2012-22 = 10 MW

Provided that the cumulative capacity to be allowed at a particular distribution transformer shall not exceed 15% of the peak capacity of the distribution transformer ;

5.2 The distribution licensee shall update distribution transformer level capacity available for connecting rooftop solar systems under net metering arrangement on yearly basis and shall provide the information on its website as well as to the Commission

6. Eligible Consumer and individual project capacity : 6.1 All eligible consumers of electricity in the area of supply of the distribution licensee can participate in the solar rooftop net metering arrangement (reference to sub-clause 2.1(i) of this Regulation).

6.2 The inter-connecting voltage level of the Grid Interactive System for various capacity ranges shall be as per relevant provision of the Arunachal Pradesh State Electricity Regulatory Commission's Electricity Supply Code Regulations - 2013.

6.3 The maximum rooftop solar system capacity to be installed at any eligible consumer premises shall be governed by the eligibility of interconnection with the grid for that eligible consumer.

Provided that the installed capacity shall be between 1KWp to 1000 KWp (1MWp).

Provided further that the installed capacity is aligned with the provisions of Arunachal Pradesh Electricity Supply Code - 2013 for permitting consumer connections

6.4 Provided that a variation in the rated capacity of the system within a range of five percent shall be allowed;

7. Interconnection with the Grid Specifications, Standards and Safety Requirements : 7.1 The distribution licensee shall ensure that :

- (a) The interconnection of the solar energy system with the distribution system of the licensee conforms to the specification and standards as provided in the Central Electricity Authority (Technical Standards for connectivity of the Distributed Generation Resources) Regulations, 2013 and as amended from time to time;
- (b) The interconnection of the solar energy system with the distribution system of the licensee conforms to the relevant provisions of the Central Electricity Authority (Measures relating to Safety and Electric Supply), Regulations, 2010, as amended from time to time
- (c) The net meter and solar meter installed conforms to the standards, specifications and accuracy class as provided in the Central Electricity Authority (Installation and Operation of Meters) Regulations, 2006, as amended from time to time and are installed in such a way that they are accessible for reading

7.2 The licensee shall, while ascertaining the feasibility and eligibility of interconnecting a Grid Interactive system of a consumer will duly consider conformity of the above mention requirement.

The supplier will inform the eligible consumer the specifications and such other details of the components including the meter and the protective devices required to be installed alongwith the solar energy system.

7.3 The licensee shall also provide in advance to an interested prospective eligible consumer a copy of the 'Net Metering Connection Agreement' annexed as Annexure-III of these Regulations, where 'technical interconnecting, safety other requirements' to be fulfilled by the consumer in respect of setting up of such system are incorporated.

7.4 The eligible consumer is to obtain the necessary clearance/approval for commissioning a Grid Interactive System, from the State Electrical Inspectorate, depending on size of solar PV generator and voltage of supply as required under Regulation 32 and Regulation 43 respectively of the Central Electricity Authority (Measures related to safety and electric supply regulations) 2010, read with connected/relevant notification of the State Government.

8. Energy Accounting and Settlement : 8.1 For each billing period, the licensee shall show the quantum of injected electricity by eligible consumer in the billing period, supplied electricity by distribution licensee in the billing period, net billed electricity for payment by the consumer for that billing period and net carried over electricity to the next billing period separately,

- (a) Provided that in the event the electricity injected exceeds the electricity consumed during the billing period, such excess injected electricity shall be carried forward to next billing period as electricity credit and may be utilized to net electricity injected or consumed in future billing periods;
- (b) Provided further that in the event the electricity supplied by the distribution licensee during any billing period exceeds the electricity generated by the eligible consumer's rooftop solar system, the distribution licensee shall raise invoice for the net electricity consumption after taking into account any electricity credit balance remaining from previous billing periods,
- (c) Provided, in case the eligible customer is under the ambit of time of day tariff, as determined by the Commission from time to time, the electricity consumption in any time block (e.g. peak hours, off-peak hours, etc.) shall be first compensated with the electricity generation in the same time block. Any cumulated excess generation over consumption in any other time block in a billing cycle shall be accounted as if the excess generation occurred during the off-peak time block
- (d) Provided also that the excess electricity measured in kilo-watt hour may only be utilized to offset the consumption measured in kilo-watt hour and may not be utilized to compensate any other fee and charges imposed by the distribution licensee as per the instructions of Arunachal Pradesh State Electricity Regulatory Commission
- (e) Provided also that the distribution licensee in addition to consumer tariff shall be eligible to raise invoice for any other charges as allowed by the Arunachal Pradesh State Electricity Regulatory Commission.

8.2 At the end of the 'settlement period' [Regulation 3 1(t)], in case there is excess electricity injection by the eligible consumer to the licensee, the licensee shall pay for the same at the average pooled purchase cost of electricity as approved by the Commission for that year

Provided also that at the beginning of each settlement period, cumulative carried over injected electricity will be reset to Zero

8.3 In case of any dispute in billing it would be settled as per provision of the APERC CGRF Regulations - 2015

9. Solar Renewable Purchase Obligation (RPO) : 9.1 The quantum of electricity generated from the solar energy system of an eligible consumer and consumed by him, shall qualify for accounting towards the Renewable Purchase Obligation (RPO) of such eligible consumer if he is an obligated entity under Arunachal Pradesh State Electricity Regulatory Commission (Renewable Purchase Obligation and its Compliance) Regulation 2012 and as amended from time to time.

9.2 The quantum of electricity generated from the solar energy system of an eligible consumer, shall qualify for accounting towards the Renewable Purchase Obligation (RPO) of the distribution licensee, if the eligible consumer is not an obligated entity under Arunachal Pradesh State Electricity Regulatory Commission (Renewable Purchase Obligation and its Compliance) Regulation - 2012 and as amended from time to time.

10. Applicability of other charges : 10.1 The rooftop solar system under net metering arrangement, whether self-owned or third party owned installed on eligible consumer premises, shall be exempted from banking, wheeling and cross subsidy surcharges

Provided that banking shall be defined as per the relevant Regulations notified by the Commission

11 Eligibility to Participate under Renewable Energy Certificate Mechanism : 11.1 The issuance of renewable energy certificate shall be as per the eligibility criteria specified under Central Electricity Regulatory Commission (Terms and Conditions for recognition and issuance of Renewable Energy Certificate for Renewable Energy Generation) Regulations, 2010 and subsequent amendments thereof.

12. Metering arrangement : 12.1 Net meter shall be installed at the interconnection points of the eligible consumers with the network of the distribution licensee.

12.2 Solar meter shall be installed at the delivery point of the solar energy system to measure the total solar electricity generated

12.3 The net meters shall be of accuracy class 1.0 or better or as per the specifications notified by the competent authority. The solar meters shall be of 0.2s class accuracy and with facility for recording meter readings using.

12.4 The solar meter and net meter shall have the facility for downloading meter readings using meter reading instrument (MRI) or wireless equipment or such other devices.

12.5 Check meter shall be installed for the solar energy system having capacity more than 20KWp and for the solar energy system of capacity less than or equal to 20 KWp, the check meter would be optional.

Provided that the cost of new/ additional meter(s) shall be borne by the eligible consumer and installed and owned by the distribution licensee

12.6 Supply and installation of meters, action on defective meter, and other matters related to meters shall be as per provisions of the APERC (Electricity Supply Code Regulations) 2013 as applicable.

12.7 The meters shall be tested, installed and sealed in accordance with the provisions of Central Electricity Authority (Installation and Operation of Meters) Regulations, 2006, as amended from time to time.

12.8 The meters installed shall be jointly inspected and sealed on behalf of both the parties and shall be tested and installed only in the presence of the representatives of the consumer and the distribution licensee.

12.9 The meter reading taken by the distribution licensee shall form the basis of commercial settlement and a copy of the meter reading statement of the net meter and solar meter shall be handed over to the consumer as soon as meter reading is taken.

13 Connection of Meters and Protective Devices : Two diagrams showing metering and other connecting arrangement of a grid interactive systems without and with battery backup are provided in Annexure I and Annexure II respectively.

The diagrams are indicative and subject to modifications to suit site conditions to resolve any technical and commercial difficulty at site. But the safety requirements like provisions of 'islanding' in case of grid failure and isolation of battery power supply when grid is connected should have to be incorporated and such diagram of actual installation indicating all components shall be conspicuously displayed in a SPV plant

14 Agreement : An agreement will be signed between the eligible consumers and DISCOM regarding setting up of the system and net metering. A model Agreement format is annexed as Annexure III.

15 Over riding Effect Not withstanding anything contained in the contrary :

- (a) in the APERC Renewable Purchase Obligation and its Compliance Regulation - 2012.
- (b) In the APERC Electricity Supply Code Regulations - 2013

Framed by the Commission under Section 181 of the Electricity Act, 2003, these regulations will have overriding effect in respect of "Grid Interactive Solar PV Systems"

16. **Penalty or Compensation** : In case of failure of net metering system, the provisions of penalty or compensation shall be as per the provisions of the Standard of Performance Regulations for Distribution Licensee notified by the Commission.

17. **Power to Remove Difficulties** : If any difficulty arises in giving effect to any of the provisions of these regulations, the Commission may, either suo motu or on an application made to it, by general or special order, direct the licensee/generator or any other person to take suitable action, not being inconsistent with the Act, which appears to the Commission to be necessary or expedient for the purpose of removing the difficulty.

18. **Power to Give Directions** : The Commission may from time to time issue such directions and orders as considered appropriate for the implementation of these Regulations.

19. **Power to Relax** : The Commission may by general or special order, for reasons to be recorded to be recorded in writing and after giving an opportunity of hearing to the parties likely to be affected may relax any of the provisions of these Regulations on its own motion or on an application made before it by an interested person.

20. **Power to Amend** : The Commission may from time to time add, vary, alter, suspend, modify, amend or repeal any provisions of these Regulations by general or special order for reasons to be recorded in writing.

21. **Saving of Inherent Powers of the Commission** : Nothing contained in these Regulations shall limit or otherwise affect the inherent powers of the Commission to adopt a procedure, which is at variance with any of the provisions of these regulations, if the Commission, in view of the special circumstances of the matter or class of matters and for reasons to be recorded in writing, deems it necessary or expedient to depart from the procedure specified in these regulations.

22. **Interpretation** : All issues arising in relation to interpretation of these regulations shall be determined by the Commission and the decision of the Commission on such issues shall be final.

By the order of the Commission

Enclo: Annexure I, II & III :

Rakesh Kumar
Secretary,
Arunachal Pradesh State
Electricity Regulatory Commission,
Nahariagun.

ANNEXURE - I

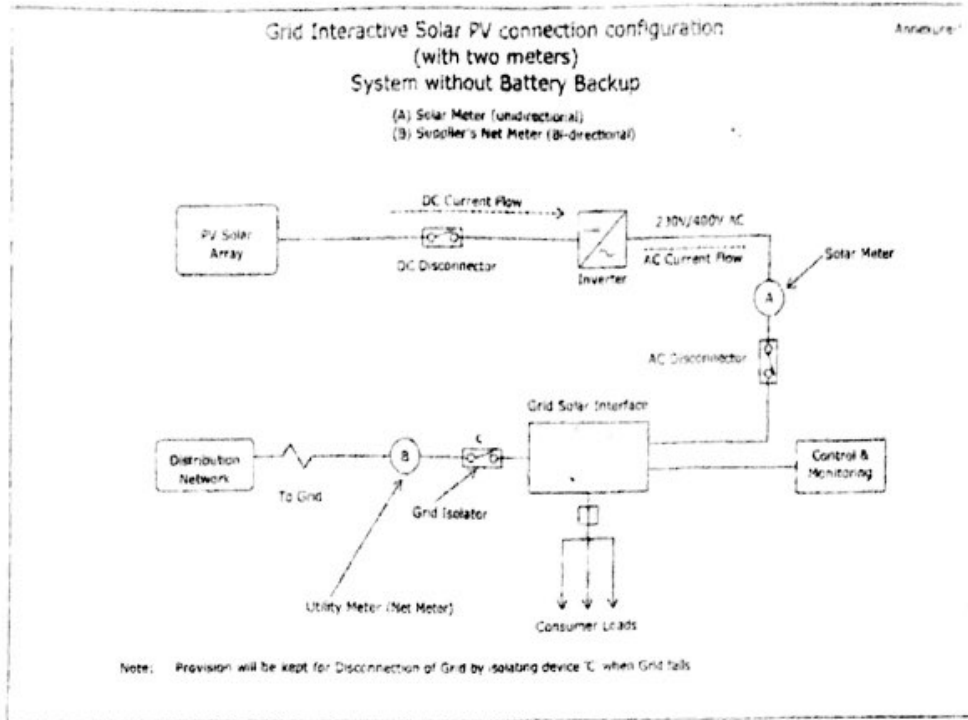

ANNEXURE - II

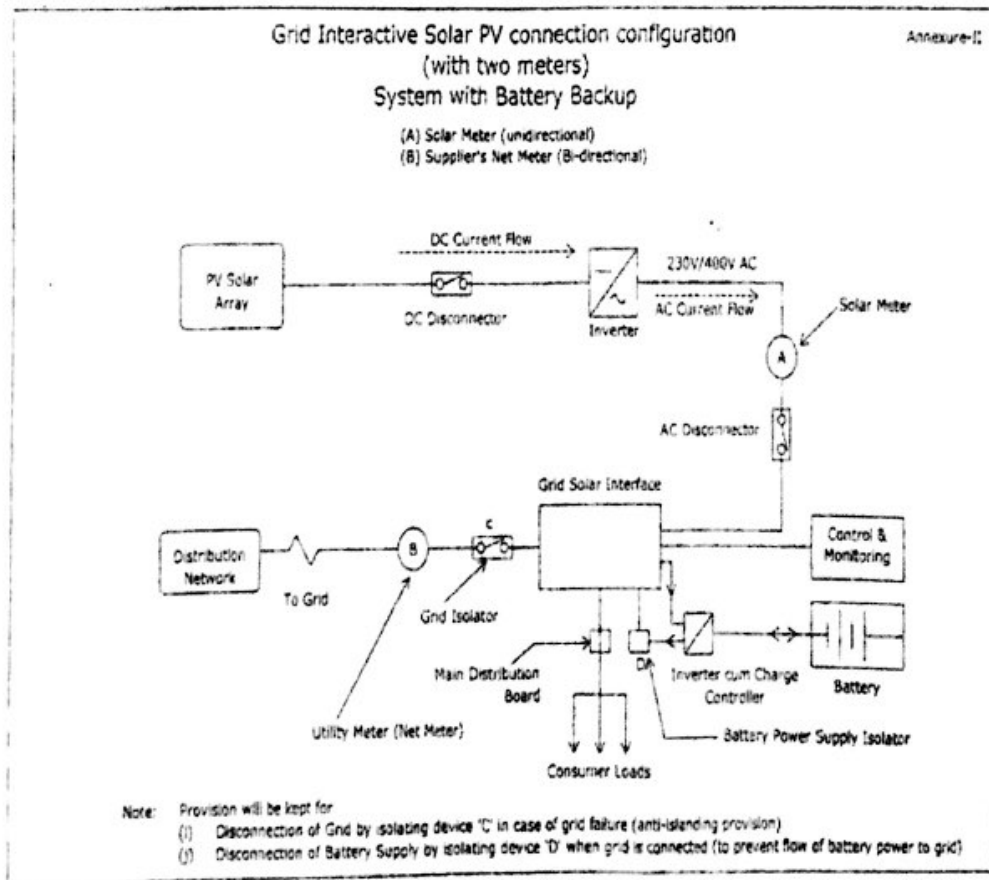

Model Net Metering Connection Agreement

This Agreement is made and entered into at (location)
 on this (date) day of (month) between

The Eligible Consumer, residing at
 (address) as first party

AND

..... Distribution Licensee (herein after called as Discom) and
 having its registered office at (address)
 as second party of the agreement

Whereas, the eligible consumer has taken the responsibility to set up or facilitate the requisite Photovoltaic system and injection system into the Discom's grid.

And whereas, the Discom agrees to benefit the eligible consumer for the electricity generated and as per conditions of this agreement and net-metering regulations.

Both the party hereby agrees to as follows

1. **Eligibility** : 1.1 Eligible consumer is required to be aware, in advance, of the standards and conditions his system has to meet for being integrated into grid/distribution system.

1.2 Eligible consumer agrees that connection of Photovoltaic system to Discom's distribution system shall be bound by requirements Arunachal Pradesh Electricity Supply Code - 2013. The grid shall continue to perform with specified reliability, security and quality as per the Central Electricity Authority's "Technical Standards for connectivity of Distributed Generation Resources Regulations, 2014" as amended from time to time and any other relevant regulations of the CEA.

1.3 The Eligible Consumer shall also agree to conform with the specifications and standards applicable to the Solar PV Systems as may be prescribed by the Ministry of New & Renewable Sources, Government of India from time to time.

2. **Technical and Interconnection Requirements** : 2.1 Eligible consumer agrees that he has installed or will install, prior to connection of Photovoltaic system to Discom's distribution system, an isolation device (both automatic and inbuilt within inverter and external manual relays) and agrees for the Discom to have access to and operation of this, if required, for repair and maintenance of the distribution system.

2.2 Eligible consumer agrees that in case of a power outage on Discom's system, photovoltaic system will shut down, unless special transfer and isolating capabilities have been installed on photovoltaic system.

2.3 All the equipment connected to distribution system must be complaint with relevant international (IEEE/IEC) or Indian standards (BIS) and installations of electrical equipment must comply with Indian Electricity rules, 1956 and Central Electricity Authority (Measures of Safety and Electricity Supply) Regulations, 2010.

2.4 Eligible consumer agrees that Discom will specify the interface/inter-connection point and metering point and metering point.

2.5 Eligible consumer agrees to adhere to following power quality measures as per International or Indian standards and/or other such measures provided by Commission/Discom

- (a) **Harmonic current** : Harmonic current injections from a generating station shall not exceed the limits specified in IEEE 519.
- (b) **Synchronization** : Photovoltaic system must be equipped with a grid frequency synchronization device.
- (c) **Voltage** : The voltage-operating window should minimise nuisance tripping and should be under operating range of 80% to 110% of the nominal connected voltage. Beyond a clearing time of 2 seconds, the Photovoltaic system must isolate itself from the grid.
- (d) **Flicker** : Operation of Photovoltaic system shouldn't cause voltage flicker in excess of the limits stated in the relevant sections of IEC standards or other equivalent Indian standards, if any.
- (e) **Frequency** : When the Distribution system frequency deviates outside the specified conditions (50.5 Hz on upper side and 47.5 Hz on lower side), the Photovoltaic system shouldn't energize the grid and should shift to island mode.
- (f) **DC Injection** : Photovoltaic system should not inject DC power more than 0.5% of full rated output at the interconnection point or 1% of rated inverter output current into distribution system under any operating conditions.
- (g) **Power Factor** : While the output of the inverter is greater than 50%, a lagging power factor of greater than 0.9 should operate.

- (h) **Islanding and Disconnection:** The Photovoltaic system in the event of voltage or frequency variations must island/disconnect itself within IEC standard on stipulated period
- (i) **Overload and Overheat:** The inverter should have the facility to automatically switch off in case of overload or overheating and should restart when normal conditions are restored.
- (j) **Paralleling device:** Paralleling device of Photovoltaic system shall be capable of withstanding 220% of the nominal voltage at the interconnection point

2.6 Eligible consumer agrees to furnish all the data such as voltage, frequency, and breaker, isolator position in his system, as and when required by the Discom. He may also try to provide facilities for online transfer of the real time operational data.

3 **Safety :** 3.1 Eligible consumer shall comply with the Central Electricity Authority (Measures Relating to Safety and Electricity Supply) Regulations 2010 and relevant provisions of National Electricity Code particularly those related to Solar PV installations

3.2 Eligible consumer agrees that the design, installation, maintenance and operation of the photovoltaic system are performed in a manner conducive to the safety of the photovoltaic system as well as the Discom's distribution system.

3.3 Due to Discom's obligation to maintain a safe and reliable distribution system, eligible consumer agrees that if it is determined by Discom that eligible consumer's photovoltaic system either causes damage to and/or produces adverse effects affecting other distribution systems' consumers or Discom's assets, eligible consumer will have to disconnect photovoltaic system immediately from the distribution system upon direction from the Discom and correct the problem at his own expense prior to a reconnection.

4 **Clearances and Approvals :** 4.1 The eligible consumer agrees to attain all the necessary approvals and clearances (environmental and grid connected related) before connecting the photovoltaic system to the distribution system.

5 **Access and Disconnection :** 5.1 Discom shall have access to metering equipment and disconnecting means of photovoltaic system, both automatic and manual, at all times.

5.2 In emergency or outage situation, where there is no access to a disconnecting means, both automatic and manual, such as a switch or breaker, Discom may disconnect service to the premise.

6 **Liabilities :** 6.1 Eligible consumer and Discom will indemnify each other for damages or adverse effects from either party's negligence or intentional misconduct in the connection and operation of photovoltaic system or Discom's distribution system

6.2 Discom and eligible consumer will not be liable to each other for any loss of profits or revenues, business interruption losses, loss of contract or loss of goodwill, or for indirect, consequential, incidental or special damages, including, but not limited to, punitive or exemplary damages, whether any of the said liability, loss or damages arise in contract, or otherwise.

6.3 Discom shall not be liable for delivery or realization by eligible consumer for any fiscal or other incentive provided by the central government.

7 **Commercial Settlement :** 7.1 All the commercial settlement under this agreement shall follow the Net metering regulations of Arunachal Pradesh State Electricity Regulatory Commission.

8 **Connection Costs :** 8.1 The eligible consumer shall bear all costs related to setting up of photovoltaic system including metering and interconnection costs. The eligible consumer agrees to pay the actual cost of modifications and upgrades to the distribution facilities required to connect photovoltaic system in case it is required.

8.2 Cost for interconnection equipment including the isolators, meters etc. are also to be borne by the eligible consumer

9 **Termination :** 9.1 The eligible consumer can terminate agreement at any time by providing Discom with 90days prior notice.

9.2 Discom has the right to terminate Agreement on 30 days prior written notice, If eligible consumer breaches a term of this Agreement and does not remedy the breach within 30 days of receiving written notice from Discom of the breach.

9.3 Eligible consumer agrees that upon termination of this Agreement, he must disconnect the photovoltaic system from Discom's distribution system in a timely manner and to Discom's satisfaction.

In the witness, where of Mr. for and on behalf of
 (Eligible consumer) and Mr. for
 and on behalf of (Discom) agree to this agreement.